

# Coupe filament

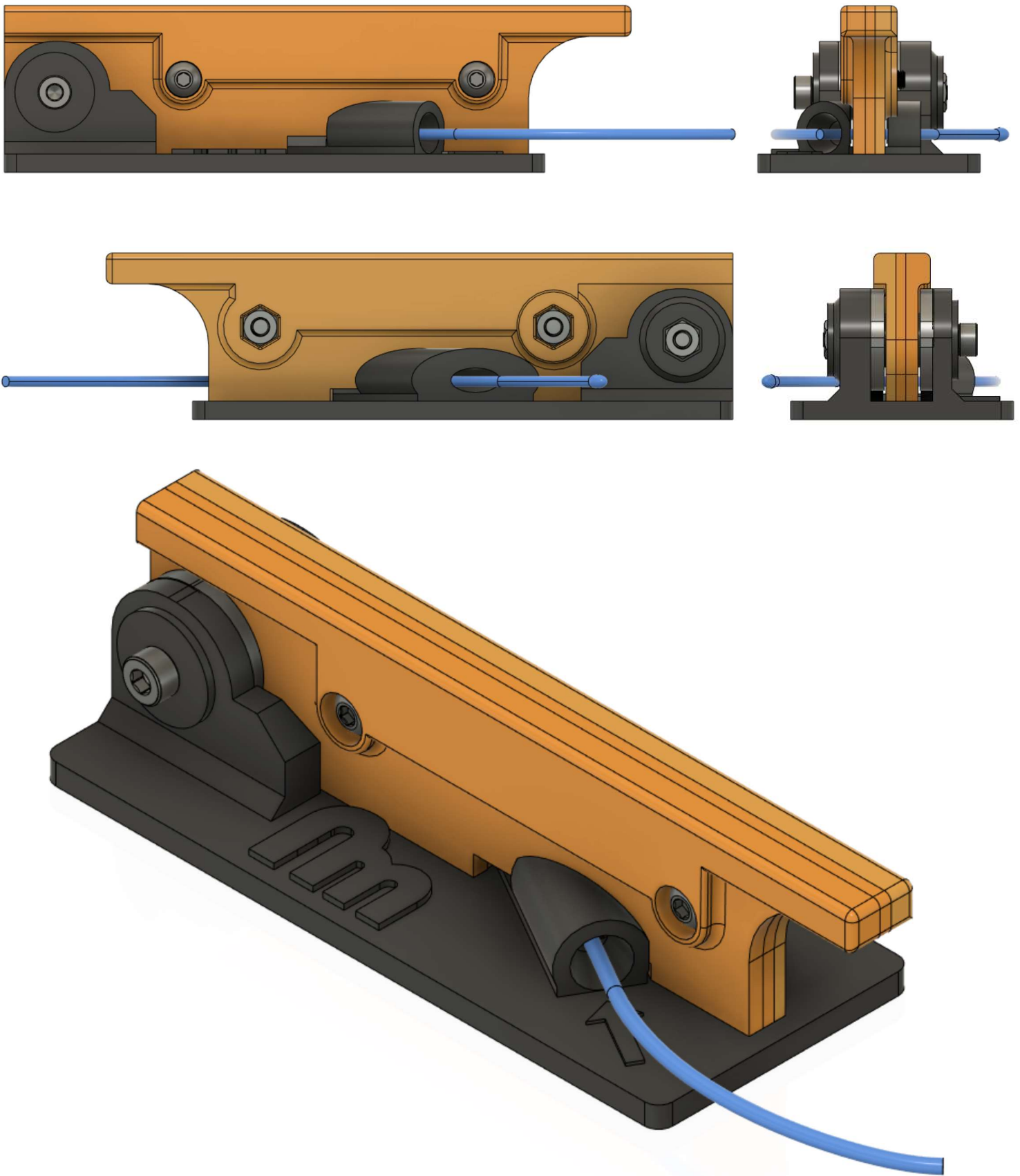

# Coupe filament



A imprimer avec  
une buse de 0.4 mm maximum

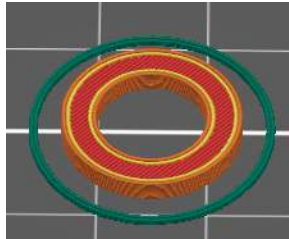

Couche 0.2 mm  
remplissage 10 %  
sans support  
Petg Noir

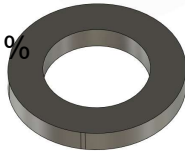

rondelle.stl

A imprimer 2X

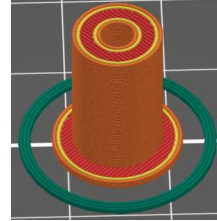

Couche 0.2 mm  
remplissage 10 %  
sans support  
Petg Noir



axe.stl

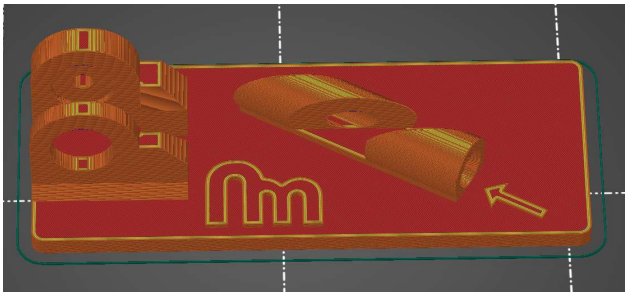

Couche 0.2 mm  
remplissage 33 %  
sans support  
Petg Noir

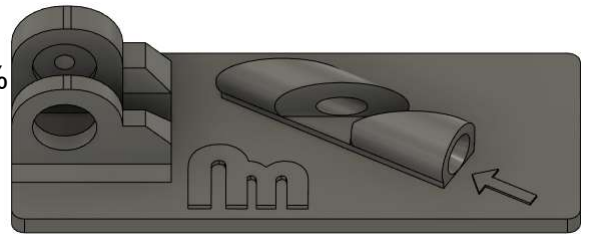

socle.stl

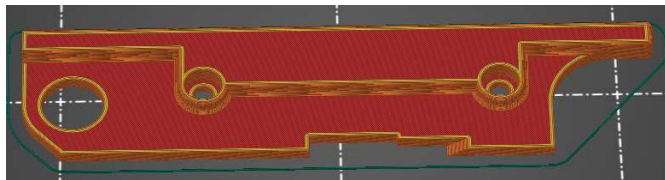

Couche 0.2 mm  
remplissage 15 %  
sans support  
Petg orange

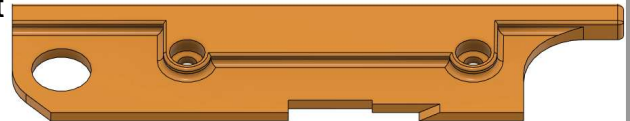

portelame.stl

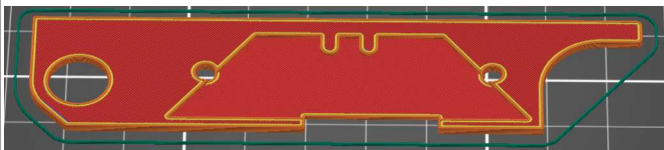

Couche 0.2 mm  
remplissage 15 %  
sans support  
Petg orange

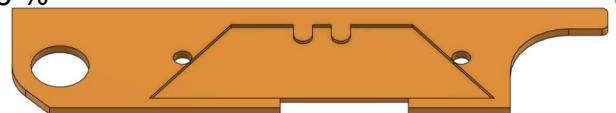

entretoise.stl

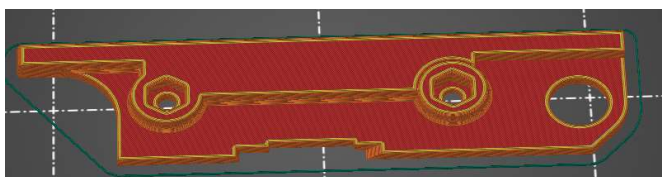

Couche 0.2 mm  
remplissage 10 %  
sans support  
Petg orange

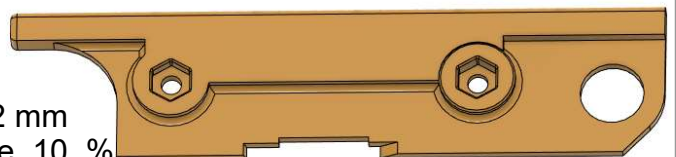

couvercle porte lame.stl

# Coupe filament

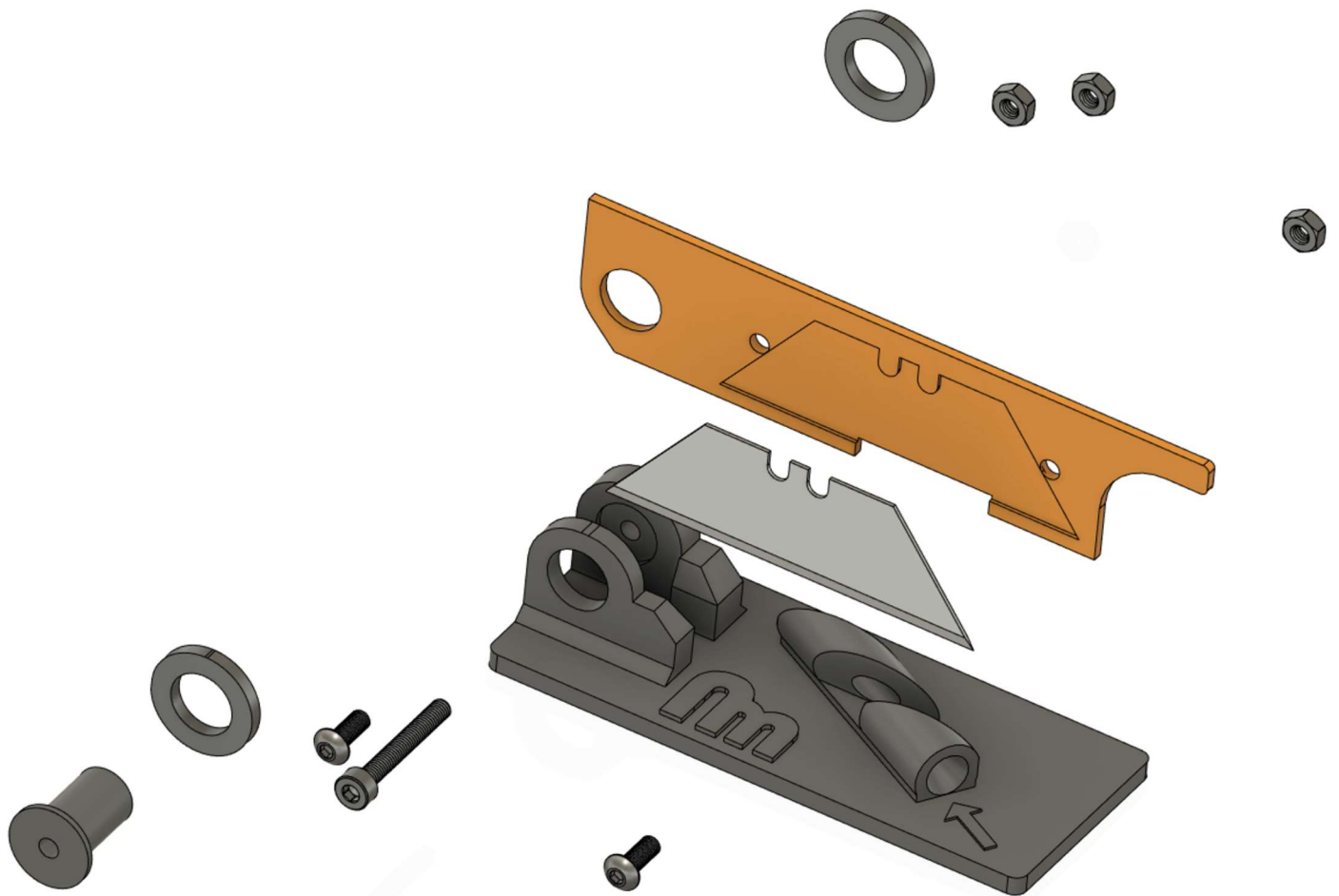

	Quantité
Vis M3 x 8 mm	2
Vis M3 x 22 mm	1
Ecrou M3	3
Lame trapéze	1