

Citröen Type H PTT

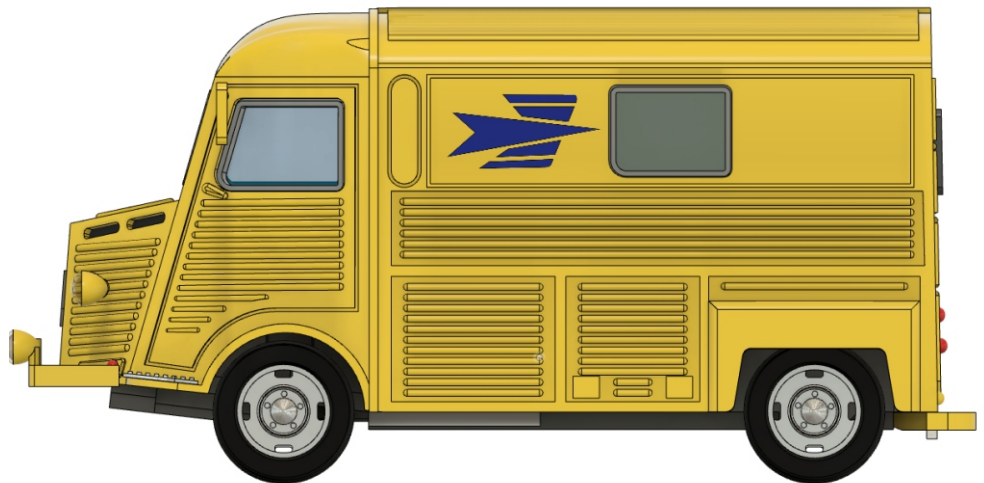

Citröen Type H PTT

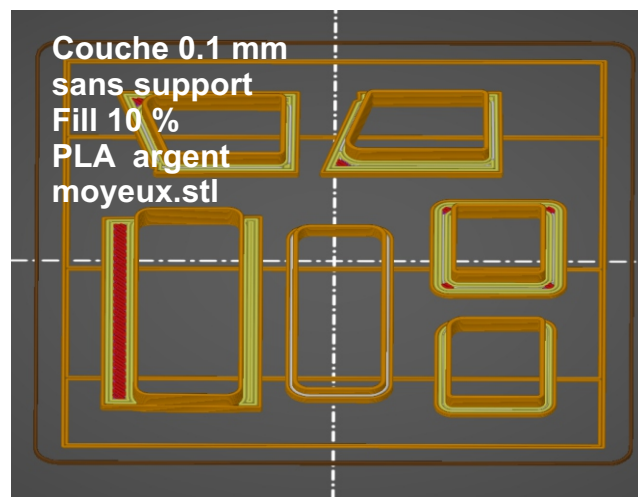
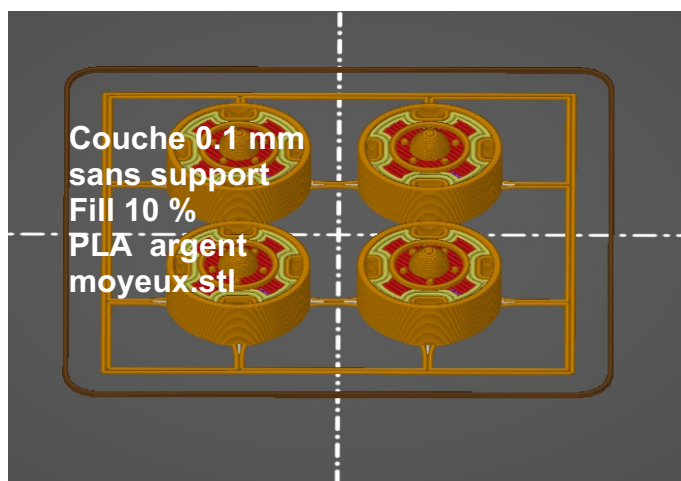
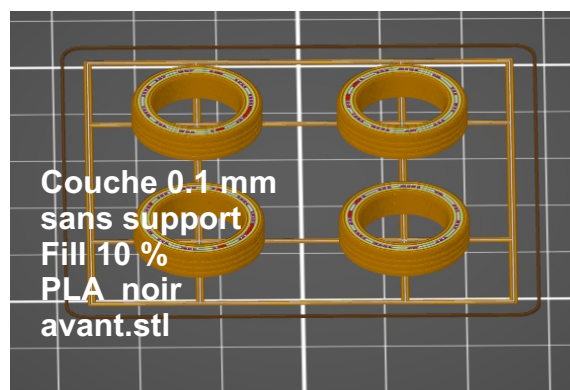
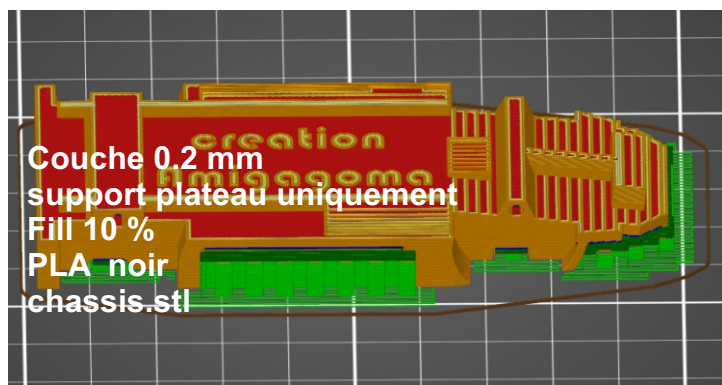
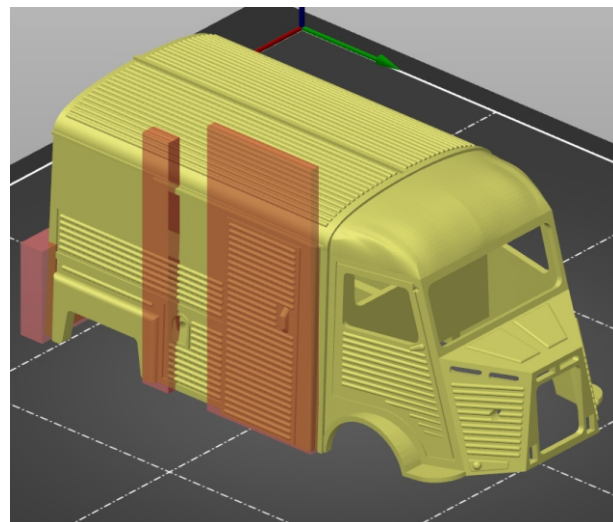
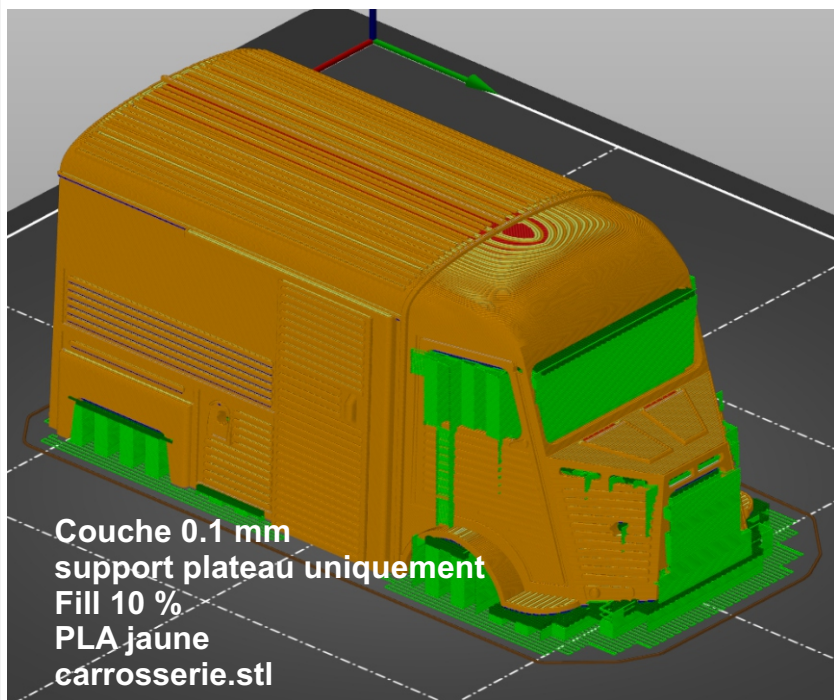

Citröen Type II PTT

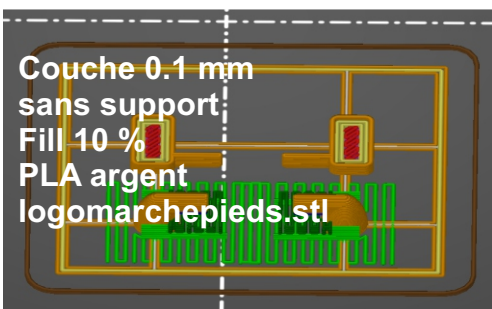
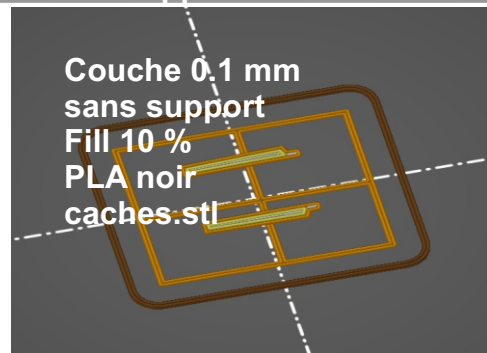
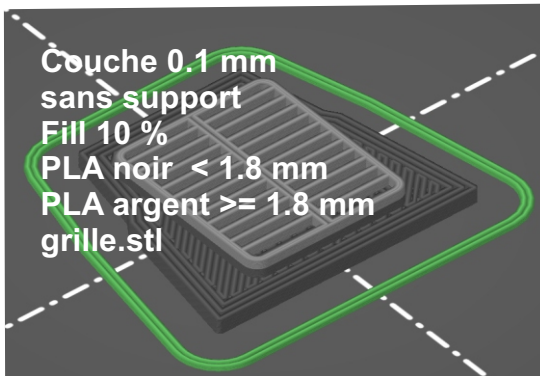
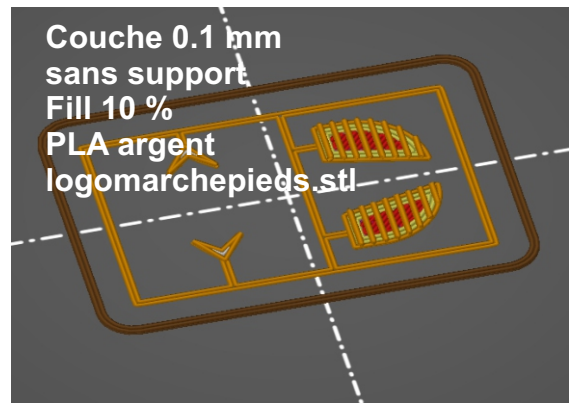
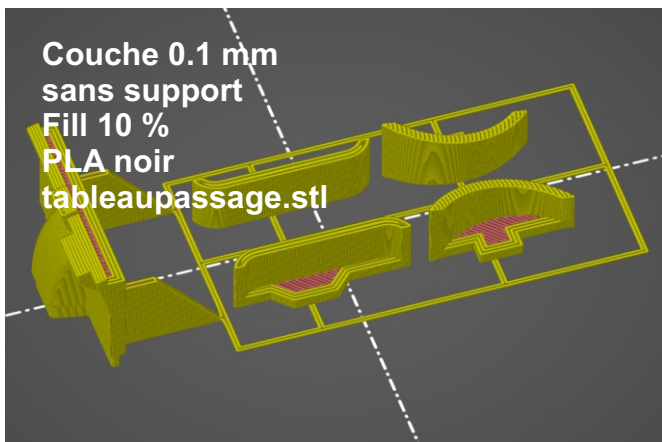
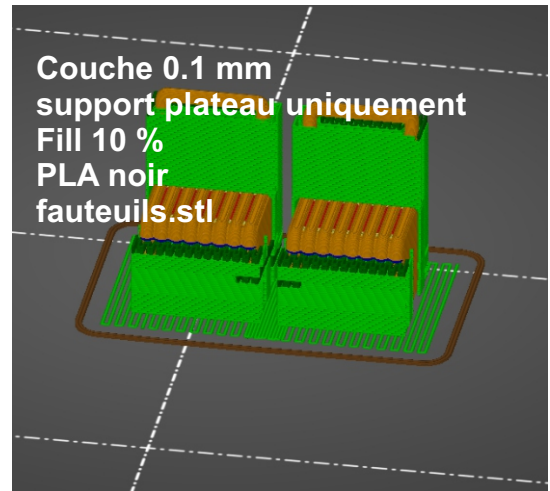
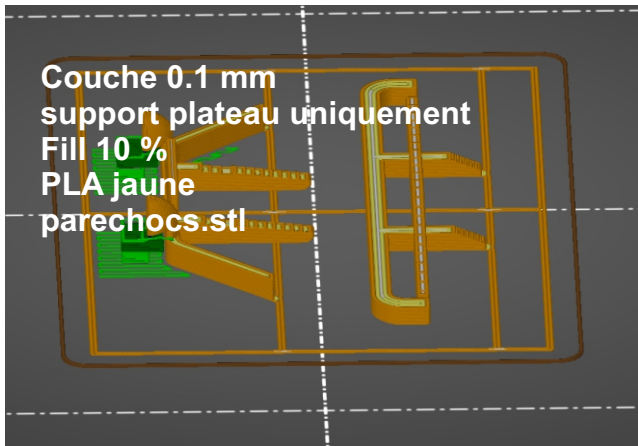

Citröen Type II PTT

1

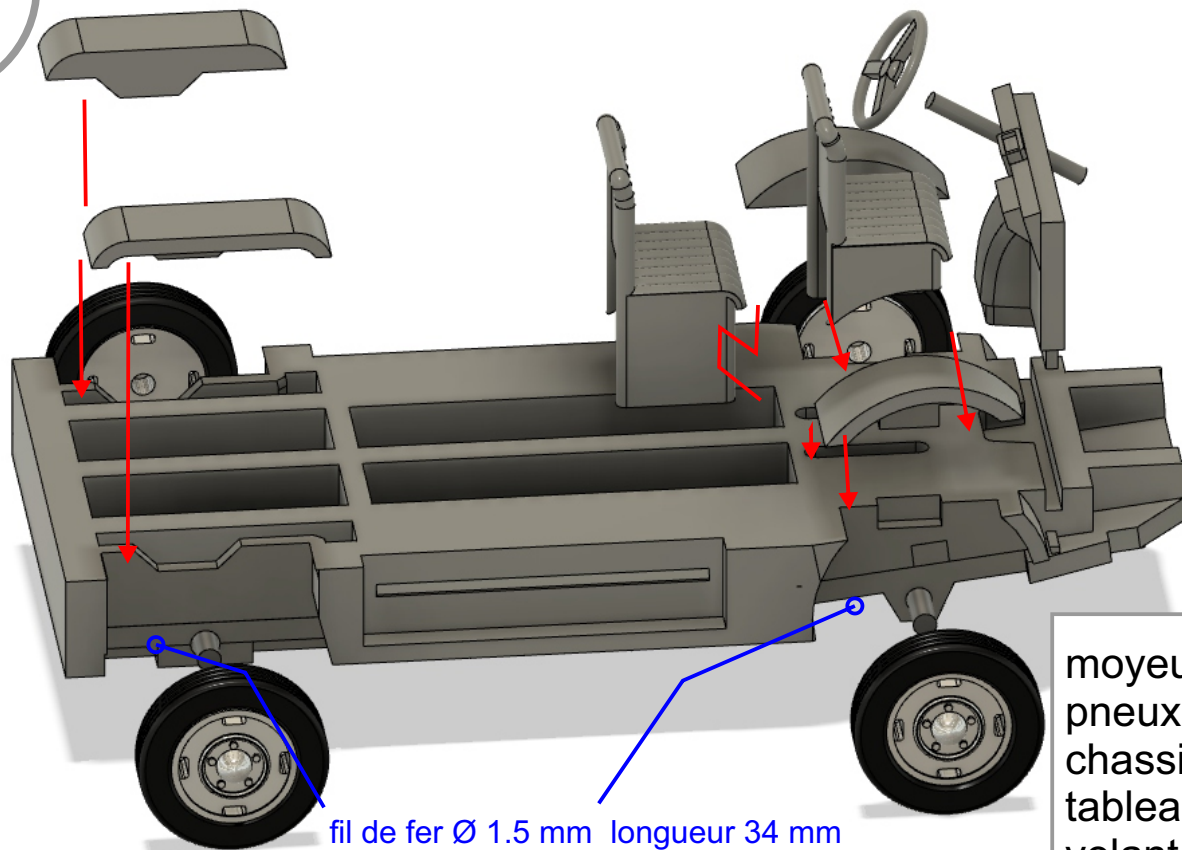

chassis

fil de fer Ø 1.5 mm longueur 34 mm

moyeux.stl
pneux.stl
chassis.stl
tableaupassage.stl
volant.stl
fauteuil.stl

2

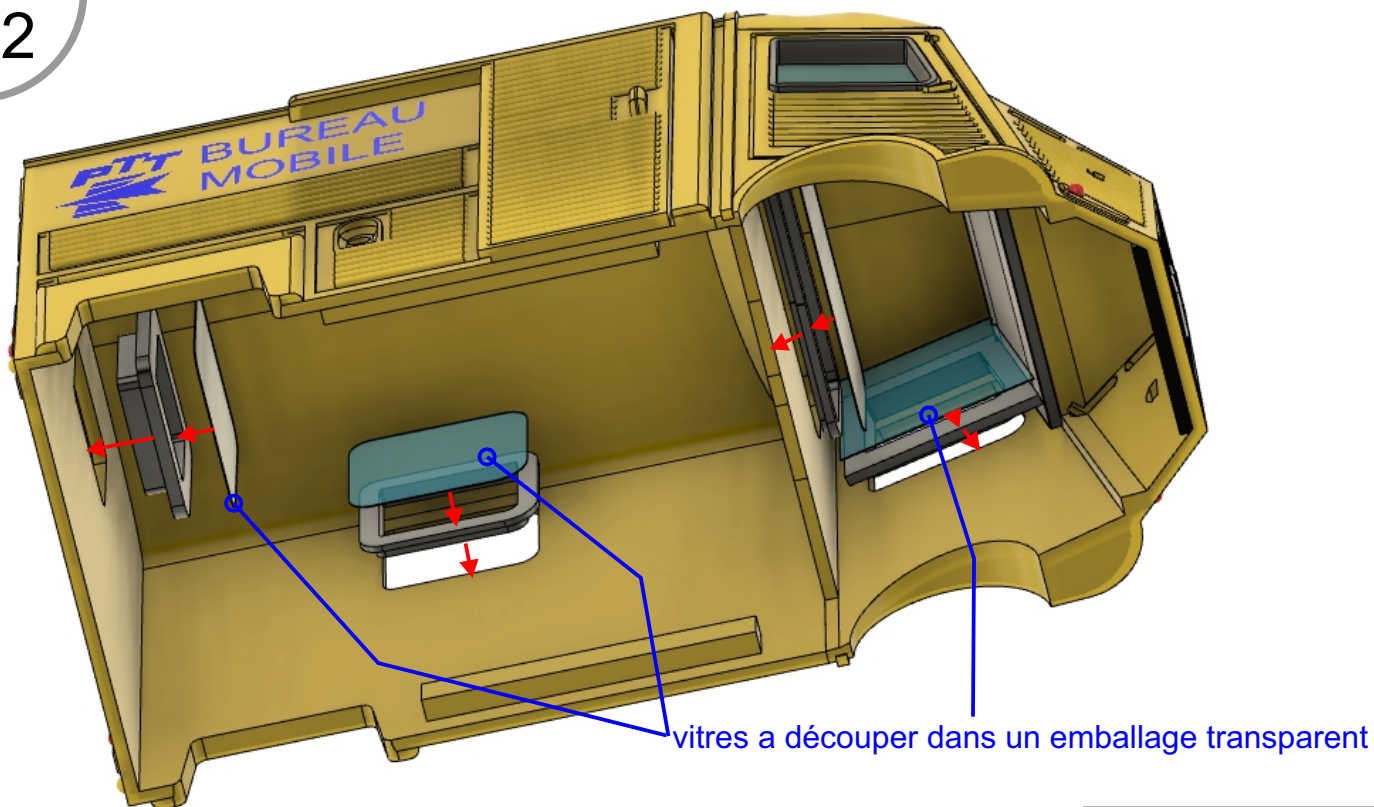

carrosserie A

vitres a découper dans un emballage transparent

carrosserie.stl
vitrage.stl

Citröen Type II PTT

1

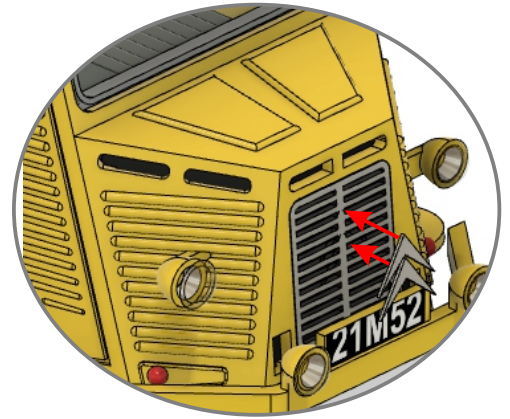
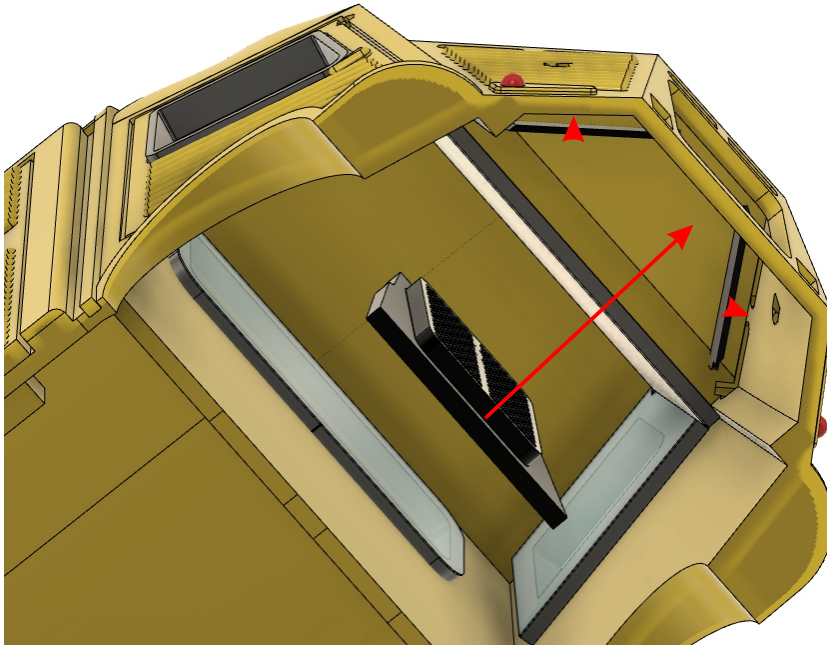

carrosserie B

carrosserie A
caches.stl
grille.stl
logomarchepieds.stl

2

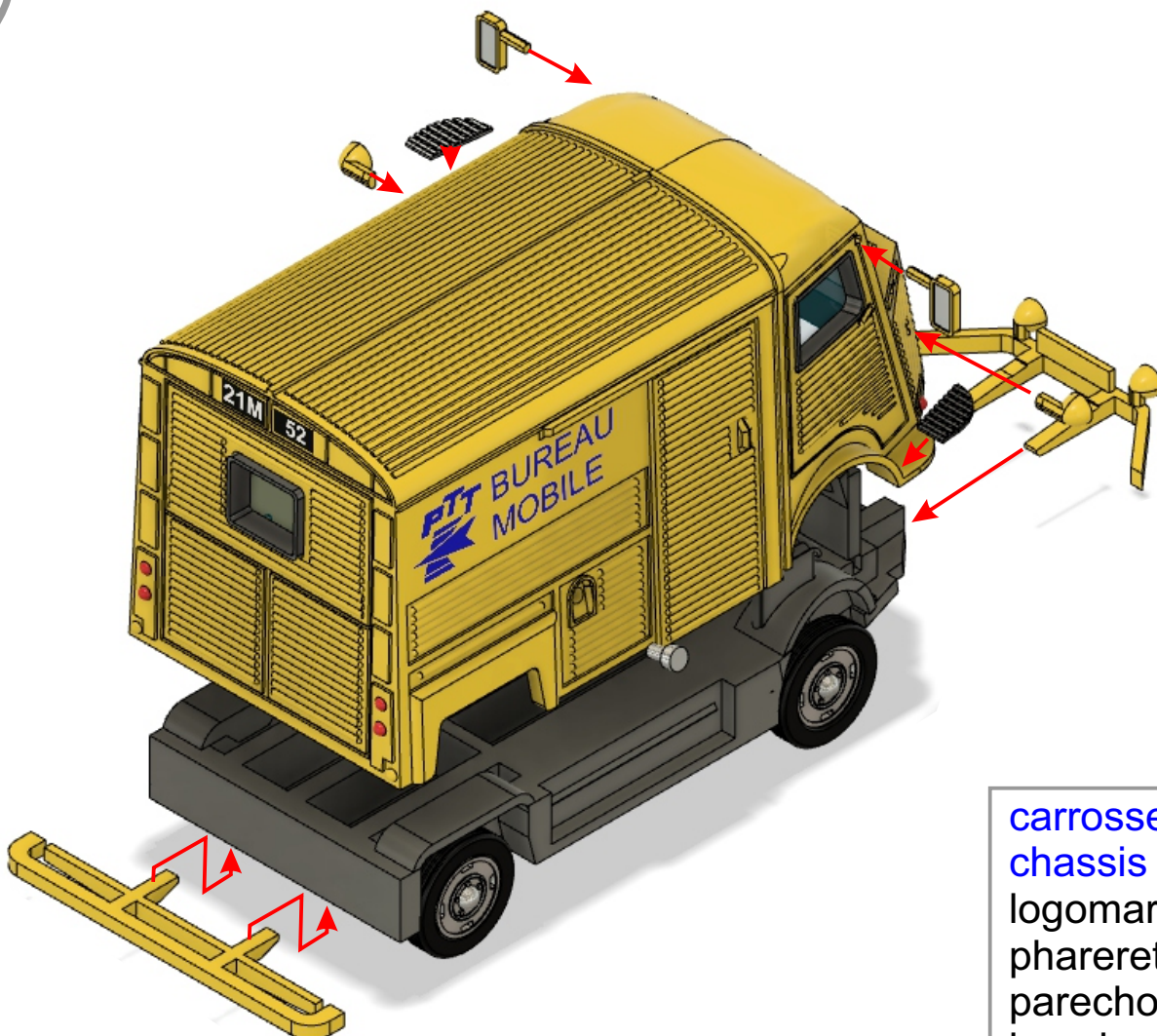

carrosserie B
chassis
logomarchepieds.stl
phareret.stl
parechocs.stl
bouchon.stl